

SERVICE MANUAL  
FOR THE  
ATARI 800XL COMPUTER

SERVICE MANUAL  
FOR THE  
ATARI 800XL COMPUTER

Electronic Dimensions Post Office Box 1846 San Luis Obispo California 93406 USA

All of the information contained in this manual is believed to be accurate and reliable. However, no responsibility shall be assumed for any consequences arising out of the use of this material.

Atari and 800XL are registered trademarks of Atari, Inc.

Reproduction of this manual in any form is prohibited.

## TABLE OF CONTENTS

<b><u>SECTION 1 - THEORY OF OPERATION</u></b>	<b>5</b>
User Interface	5
Mechanical Theory	9
Electrical Theory	9
6502C CPU Microprocessor	10
Alphanumeric Television Interface Controller (ANTIC)	11
Graphic Television Interface Adaptor (GTIA)	12
POT KEYboard Integrated Circuit (POKEY)	13
Peripheral Interface Adaptor (PIA)	14
Memory (ROMs and DRAMs)	15
Memory Management Unity (MMU)	15
Operating System ROM	15
RF Modulator	15
Monitor Output	17
Power Supply	17
System Interface	18
Serial Input/Output (SIO) Interface	18
Controller Jack Interfaces	19
Parallel Bus Interface (PBI)	20
Cartridge Interface	21
Keyboard Interface	22
<b><u>SECTION 2 - SELF TESTING</u></b>	<b>23</b>
Overview	23
Equipment Needed	23
Self Test Features	23
Description of Self Tests	24
Memory Test	24
Audio Visual Test	25
Keyboard Test	25
All Tests	25
<b><u>SECTION 3 - DISASSEMBLY/ASSEMBLY</u></b>	<b>26</b>
<b><u>SECTION 4 - TROUBLESHOOTING</u></b>	<b>27</b>
A Guide to Aid in the Rapid Diagnosis of Problems	
<b><u>SECTION 5 - SCHEMATIC AND PARTS LIST</u></b>	<b>31</b>
Parts List	32

## SECTION 1

### THEORY OF OPERATION

The Atari 800XL™ is an enhanced version of the existing ATARI Computer Systems. It can be used with any of the existing Atari peripheral devices used with the 400™/600XL™/800™/1200XL™ Computers.

The printed circuit board contains 64K of RAM, an operating systems that contains one 16K X 8 ROM and an on-board Atari BASIC programming language I.C. The console contains the keyboard and four function keys (including a HELP key), plus a RESET key, a detachable (RF) TV interface cable, connector jack for daisy-chaining peripherals and connecting hand controllers, a single cartridge slot, one status LED (POWER), a 5 pin DIN Monitor Jack, and a parallel bus interface (PBI).

#### USER INTERFACE

The Atari 800XL is a general purpose microcomputer that uses a 6502C microprocessor. The 800XL console is the central processing unit for its respective system.

The right side panel contains the controller jacks that accept the Atari X-Y joysticks and paddle controllers.

The rear panel contains the serial input/output (SIO) jack, the parallel bus interface, the RF jack, the monitor jack, the channel 2-3 switch, the power in jack, and the power switch (On/Off).

The console has a 3/4 stroke, 56 key, alphanumeric keyboard, that includes special characters and controls, space bar, four function keys, HELP key, and power indicator. The function and HELP keys are discussed below.

#### FUNCTION KEYS

HELP - Returns to main self-test menu from individual test and for future software development for user "help" functions. If you are familiar with 1200XL operation, this key does not function the same.

OPTION - Allows the player to choose variations of a program. If the OPTION Key is not depressed and held at the time the computer is turned ON, the built-in BASIC is automatically enabled. If the OPTION key is depressed and held at the same time the computer is turned ON, the on board BASIC is disabled and, when there is no cartridge or diskette in the system, the

Self-Test menu appears.

RESET - Interrupts and restarts the operating system (OS) or cartridge. When pressed while the computer is ON, this key enables the BASIC.

SELECT - Selects different program or game variations.

START - Starts the game or program.

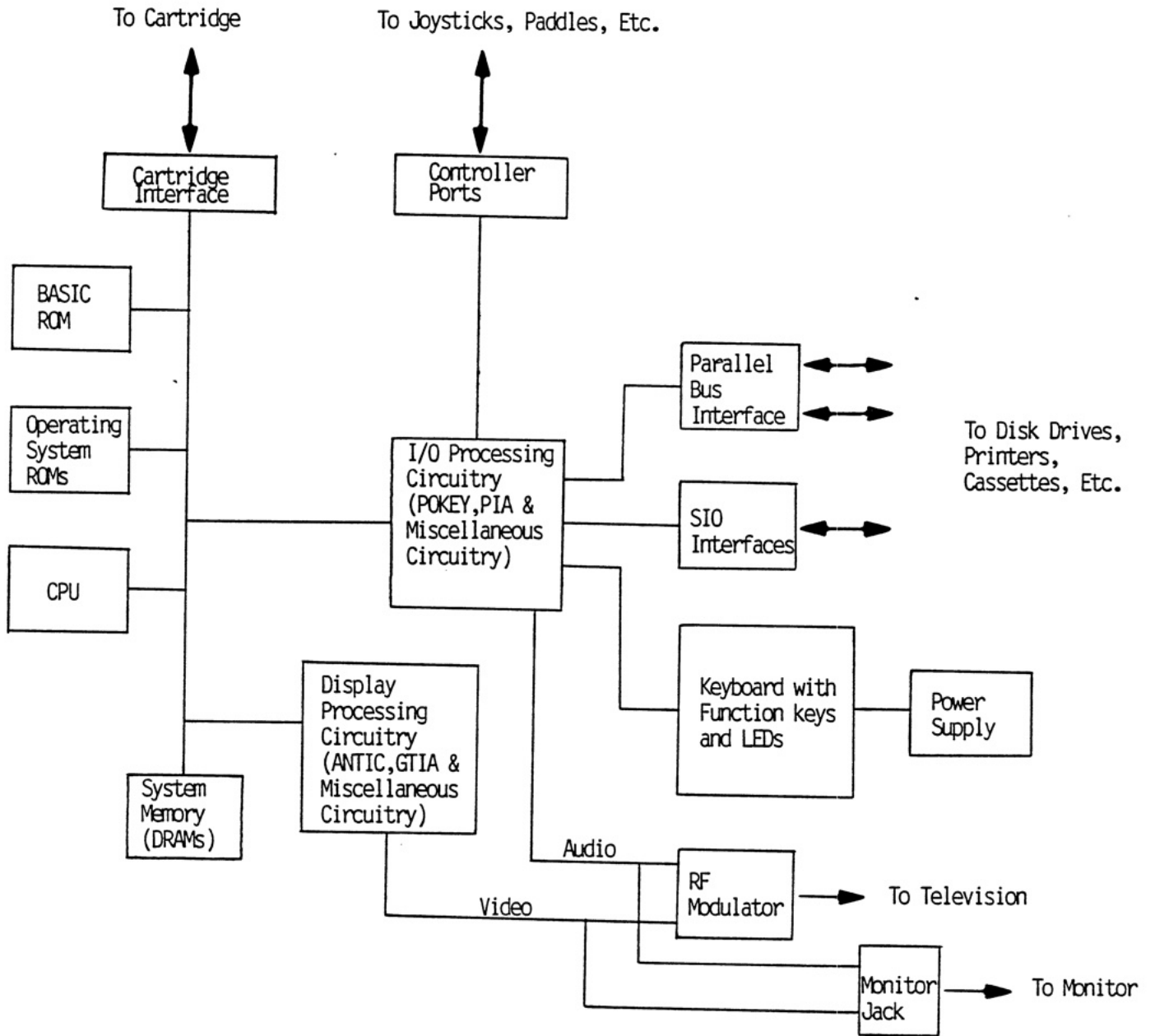

System Block Diagram

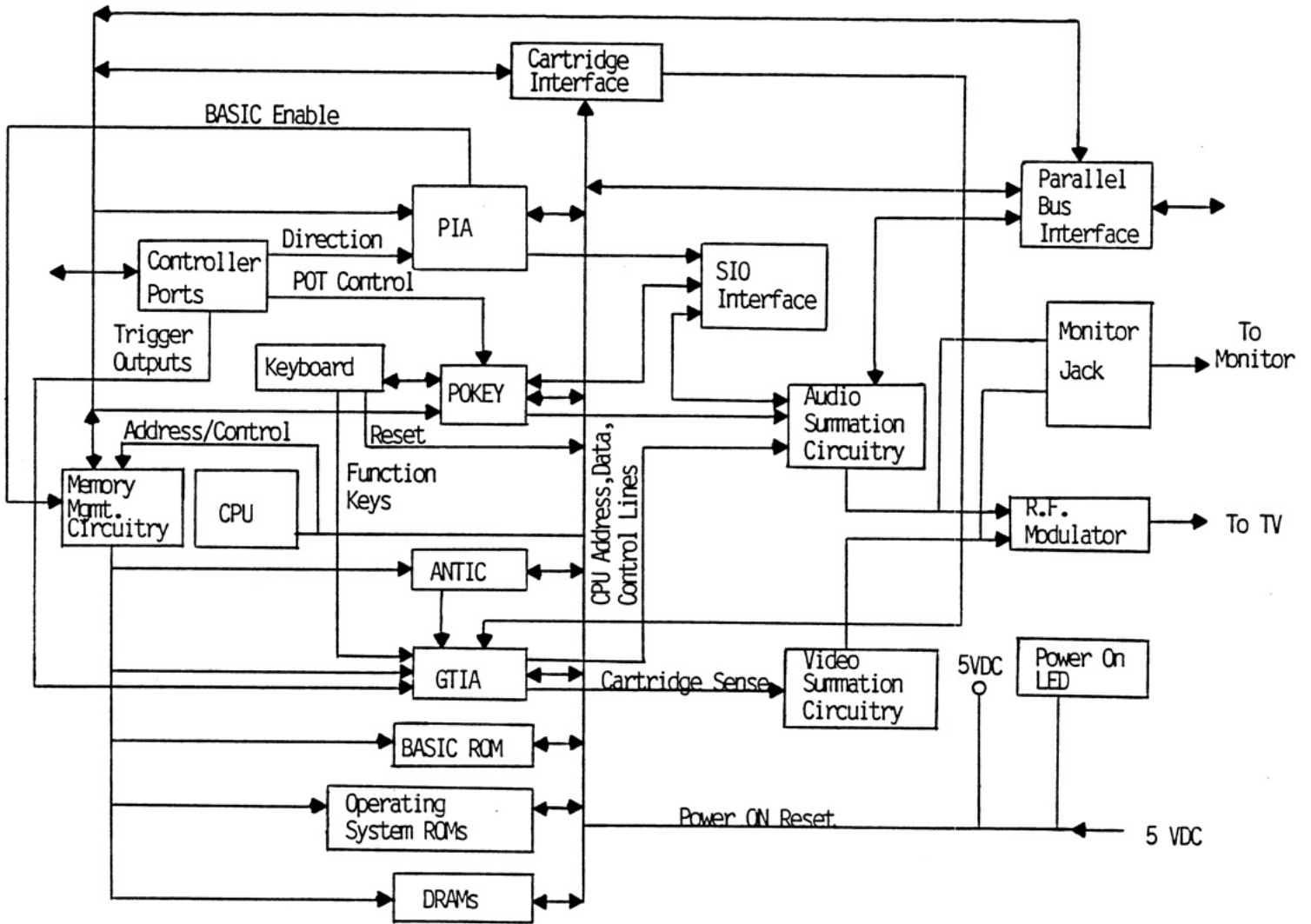

Functional Block Diagram



## MECHANICAL THEORY

The 800XL computer console contains a single motherboard which houses all the chips of the system and provides connectors for interfacing external modules to the console. It includes the CPU, RAM, OS and BASIC ROM's. The motherboard uses a common address bus, data bus and clock lines. The sixteen-line address bus allows the microprocessor to directly address 64K memory locations. The eight-line data bus provides the communication and data path between the functional modules. The power is provided by an external power supply and routed throughout the console.

The keyboard is the user interface with the computer.

The keyboard connects to the PC Board by a 24-connector ribbon cable.

All peripherals connect to the 800XL either through the SIO connector or the PBI. Power enters through the 7-Pin DIN connector on the rear panel. Power On/Off is controlled by the ON/OFF switch on the rear panel. RF to the TV switchbox arrives from an RCA phonoconnector and RF cable. Composite Video composite luminance, and audio signals to the monitor arrive from a 5 pin DIN monitor jack on the rear panel.

## ELECTRICAL THEORY

### DIGITAL HARDWARE

The digital hardware consists of:

- \* The 6502C CPU microprocessor
- \* The Alphanumeric Television Interface Controller (ANTIC)
- \* The Graphics Television Interface Adaptor (GTIA)
- \* The POT KEYboard Integrated Circuit (POKEY)
- \* The Peripheral Interface Adaptor (PIA)
- \* The Memory (Operating System ROM, 64K RAM, Atari BASIC ROM, Rev. B)
- \* Miscellaneous Logic
  - Memory Management Unit (MMU)
  - Delay Line
- \* Parallel Bus Interface (PBI)

6502C CPU Microprocessor

The 6502C CPU microprocessor contains register flags, interconnections, arithmetic logic, control logic, and all recognized operation codes. The characteristics of the microprocessor include:

- \* Byte-oriented structure
- \* Decimal and binary arithmetic modes
- \* Integral clock circuit
- \* Seven addressing modes
- \* Single +5 volt DC power requirement
- \* Stack pointer
- \* Two interrupt levels
- \* 151 opcodes
- \* 64K address range
- \* True Indexing

Ground	VSS	1 ●	40	RES	Reset
Ready Input	RDY	2	39	FPH2	Phase 2 Clock
Phase 1 Clock	FPH1	3	38	S0	Set Overflow
Interrupt Request	IRQ	4	37	FPH0	Phase 0 Clock (in)
	NC	5	36	R/W	Read/Write
Non Maskable Input	NMI	6	35	HALT	HALT Input
	NC	7	34	NC	
+5V Power	VCC	8	33	D0	Data Bus
Address Bus	A0	9	32	D1	Data Bus
Address Bus	A1	10	31	D2	Data Bus
Address Bus	A2	11	30	D3	Data Bus
Address Bus	A3	12	29	D4	Data Bus
Address Bus	A4	13	28	D5	Data Bus
Address Bus	A5	14	27	D6	Data Bus
Address Bus	A6	15	26	D7	Data Bus
Address Bus	A7	16	25	A15	Address Bus
Address Bus	A8	17	24	A14	Address Bus
Address Bus	A9	18	23	A13	Address Bus
Address Bus	A10	19	22	A12	Address Bus
Address Bus	A11	20	21	VSS	Ground

6502C (Modified)

### Alphanumeric Television Interface Controller (ANTIC)

The ANTIC Display Processor is a custom display microprocessor with an instruction set customized for graphics generation. It also has the ability to control the ADDRESS & DATA bus and RAM Refresh.

Ground	VSS	1 ●	40	D4	Data Bus
Alphanumeric Data	$\overline{ANO}$	2	39	D5	Data Bus
Alphanumeric Data	$\overline{ANT}$	3	38	D6	Data Bus
Light Pen	$\overline{LP}$	4	37	D7	Data Bus
Alphanumeric Data	$\overline{AN2}$	5	36	$\overline{RST}$	Reset
System Reset	$\overline{RNMT}$	6	35	$\overline{F00}$	Fast Phase 0 Clock
Interrupt Output	$\overline{NMT}$	7	34	$\overline{00}$	Phase 0 Clock
Refresh	$\overline{REF}$	8	33	D3	Data Bus
HALT	$\overline{HALT}$	9	32	D2	Data Bus
Address Bus	A3	10	31	D1	Data Bus
Address Bus	A2	11	30	D0	Data Bus
Address Bus	A1	12	29	$\overline{02}$	Phase 2 Clock
Address Bus	A0	13	28	A4	Address Bus
Read/Write	$\overline{R/W}$	14	27	A5	Address Bus
Ready Output	RDY	15	26	A6	Address Bus
Address Bus	A10	16	25	A7	Address Bus
Address Bus	A12	17	24	A8	Address Bus
Address Bus	A13	18	23	A9	Address Bus
Address Bus	A14	19	22	A11	Address Bus
Address Bus	A15	20	21	VCC	+5V Power

ANTIC

Graphic Television Interface Adeptor (GTIA)

The GTIA interfaces with the ANTIC processor on one side and with the video summation circuitry on the other. Its primary task is to generate color and luminance signals from the bit stream it receives from the ANTIC Display Processor. It also processes the Function keys, provides the keyboard "beep" via the TV speaker and monitors controller Trigger lines.

Address Bus	A1	1 ●	40	A2	Address Bus
Address Bus	A0	2	39	A3	Address Bus
Ground	VSS	3	38	A4	Address Bus
Data Bus	D3	4	37	D4	Data Bus
Data Bus	D2	5	36	D5	Data Bus
Data Bus	D1	6	35	D6	Data Bus
Data Bus	D0	7	34	D7	Data Bus
Trigger 0	T0	8	33	R/W	Read/Write
Trigger 1	T1	9	32	CS	Chip Select 1
Trigger 2	T2	10	31	LUM 3	Luminance Line
Trigger 3	T3	11	30	Φ2	Phase 2 Input
Option	S0	12	29	F00	Clock Out
Start	S1	13	28	OSC	Oscillator Input
Select	S2	14	27	VCC	Power
Keyboard Click	S3	15	26	HALT	HALT
PAL Color Delay	PAL	16	25	CSYNC	Output Sync.
Color Delay	CADJ	17	24	LUM 2	Luminance 2 Output
Alphanum. Data 0	AN0	18	23	LUM 1	Luminance 1 Output
Alphanum. Data 1	AN1	19	22	LUM 0	Luminance 0 Output
Alphanum. Data 2	AN2	20	21	COL	Color

GTIA

POT KEYboard Integrated Circuit (POKEY)

The POKEY is a custom Large Scale Integrated circuit (LSI) chip. It is used for audio generation, Serial Input/Output (SIO) Data and Clocks, POT Controller interface scan, and keyboard scan.

Ground	VSS	1 ●	40	D2	Data Bus
Data Bus	D3	2	39	D1	Data Bus
Data Bus	D4	3	38	D0	Data Bus
Data Bus	D5	4	37	AUDIO	Audio Out
Data Bus	D6	5	36	A0	Address Bus
Data Bus	D7	6	35	A1	Address Bus
Phase 2 Clock	Ø2	7	34	A2	Address Bus
Pot Scan	P6	8	33	A3	Address Bus
Pot Scan	P7	9	32	R/W	Read/Write
Pot Scan	P4	10	31	$\overline{CS}$ T	Chip Select
Pot Scan	P5	11	30	$\overline{CS}$ Ø	Chip Select
Pot Scan	P2	12	29	$\overline{IRQ}$	Interrupt Request
Pot Scan	P3	13	28	SOD	Serial Output Data
Pot Scan	PØ	14	27	ACLK	Serial Output Clock
Pot Scan	P1	15	26	BCLK	Bidirectional Clock
Keyboard Response	$\overline{KR2}$	16	25	$\overline{KR1}$	Keyboard Response
+5V Power	VCC	17	24	SID	Serial Input Data
Keyboard Scan	$\overline{K5}$	18	23	$\overline{KØ}$	Keyboard Scan
Keyboard Scan	$\overline{K4}$	19	22	$\overline{K1}$	Keyboard Scan
Keyboard Scan	$\overline{K3}$	20	21	$\overline{K2}$	Keyboard Scan

POKEY

Peripheral Interface Adaptor (PIA)

The PIA is a general purpose Input/Output (I/O) chip. It monitors the X-Y controller interfaces and the SIO control lines. In certain applications it may control the MMU logic.

Ground	VSS	1 •	40	CA1	Control Line
Controller Input	PA0	2	39	CA2	Motor Control Output
Controller Input	PA1	3	38	<u>IRQA</u>	Interrupt Request(Out)
Controller Input	PA2	4	37	<u>IRQB</u>	Interrupt Request(Out)
Controller Input	PA3	5	36	A1	Address Line
Controller Input	PA4	6	35	A0	Address Line
Controller Input	PA5	7	34	<u>RESET</u>	Reset Input
Controller Input	PA6	8	33	D0	Data Line
Controller Input	PA7	9	32	D1	Data Line
Enable/Disable Output	PB0	10	31	D2	Data Line
Not Used	PB1	11	30	D3	Data Line
Output to LED 1	PB2	12	29	D4	Data Line
Not Used	PB3	13	28	D5	Data Line
Not Used	PB4	14	27	D6	Data Line
Not Used	PB5	15	26	D7	Data Line
Not Used	PB6	16	25	O2	Clock Input
Self Test Output	PB7	17	24	CS1	Chip Select Input
Control Line	CB1	18	23	<u>CS2</u>	Chip Select Input
<u>Command</u> Output	CB2	19	22	CS0	Chip Select Clock Input
+5V Supply Voltage	VCC	20	21	R/W	Read/Write

PIA

## MEMORY (ROMS AND DRAMS)

### BASIC ROM

The Atari 800XL has built-in Atari BASIC (Rev. B) residing in an 8K X 8 ROM. This is equivalent to having an Atari BASIC cartridge permanently plugged into the console. Any cartridge plugged into the computer takes precedence over the built-in BASIC.

### DRAMS

The 800XL Dynamic Random Access Memories (DRAMS) consist of eight 64K X 1 DRAMS.

### MEMORY MANAGEMENT UNIT (MMU)

The memory management unit (MMU) address decoding circuitry consists of a PLA (Programmable Logic Array) I.C., one 3 to 8 decoder and a few gates. The input to the circuitry includes the address lines A8 through A15 as well as control signals, such as ROM enable (from PIA) and DRAM refresh from ANTIC. Some of the most important outputs of this circuitry include select signals for the GTIA, POKEY, PIA, OS ROM, DRAMS, BASIC and cartridge.

### O.S. ROM

The 800XL operating system is resident in one 16K X 8 ROM. The ROM address inputs are from CPU address lines A0 through A13. The chip selects from the address decoding circuitry and generates data on CPU data lines D0 through D7. The ROM requires a power input of +5 volts.

### RF MODULATOR

The RF modulator accepts the composite video from the video summation circuitry and the mono-aural audio signals and produces a modulated signal suitable for the television.

With a 75 Ohm termination, the modulated signal has the following characteristics:

Maximum Voltage: 2mV  
Minimum Voltage: 1mV

Audio Sound Carrier Frequency: 4.5 MHz

Frequency Response:

Channel 2 -

Band: 6 MHz

Video Carrier: 55.25 MHz

Audio Carrier: 59.75 MHz

Channel 3 -

Band: 6 MHz

Video Carrier: 61.25 MHz

Audio Carrier: 65.75 MHz



## MONITOR OUTPUT

The 5 pin DIN monitor output jack (J2) accepts the composite video and the composite luminance signals from the GTIA video summation circuitry and the amplified mono-aural audio signals from POKEY. J2 then transfers these signals directly to the input of the video monitor via a 5 pin DIN monitor cable.

The output signals have the following characteristics:

	<u>Min. Voltage</u>	<u>Max. Voltage</u>
Composite Video	750 mV P-P	1 V P-P
Composite Luminance	1.2V P-P	1.5V P-P
Audio	600 mV P-P	750 mV P-P

## POWER SUPPLY

The power supply connector is a 7-pin DIN connector.

The Atari 800XL has an external power supply that accepts 110 VAC (nominal) from the power lines and provides +5 VDC output (+/- 2%). The maximum rating for the supply is +5 volts and 1.2 amps.

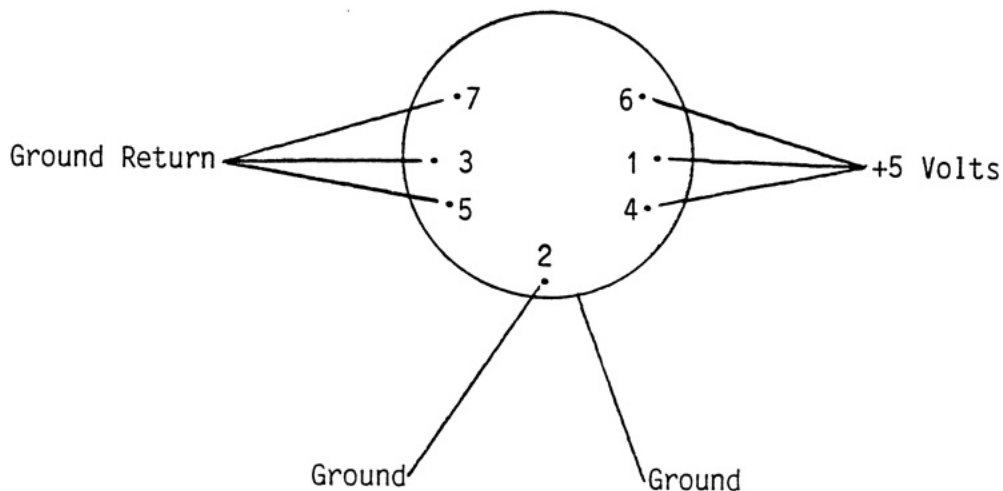

Power Supply Connector Pin Assignments  
(Looking Toward Computer)

## SYSTEM INTERFACE

The 800XL provides the following interfaces:

- \* Serial input/output (SIO)
- \* Controller Jacks
- \* Parallel Bus Interface (PBI)
- \* Cartridge Interface
- \* Keyboard Interface

## SERIAL INPUT/OUTPUT (SIO) INTERFACE

The Atari 800XL communicates with peripheral devices via an asynchronous serial port (19.2K Baud rate max.). Data is transmitted and received as eight bits of serial data. LSB is sent first preceded by a logic zero start bit and succeeded by a logic one stop bit. The serial data out is transmitted or received as positive logic. The serial data out line always assumes its new state when the serial clock out line goes high. Clock out goes low in the center of data out.

The bus protocol specifies that all commands must originate from the computer and that peripherals present data on the bus only when commanded to do so. Every bus operation goes to completion before another bus operation is initiated. An error detected at any point in the bus operation aborts the entire sequence. A bus operation consists of the following elements:

- Command Frame (From Computer)
- Command Frame
  - 1) Data Send
  - 2) Data Receive
  - 3) Immediate (No Data-Command Only, i.e., status)
- Acknowledge Frame (From Peripheral)
- Optional Data Frame (To Or From Computer)
- Complete Frame (From Peripheral)

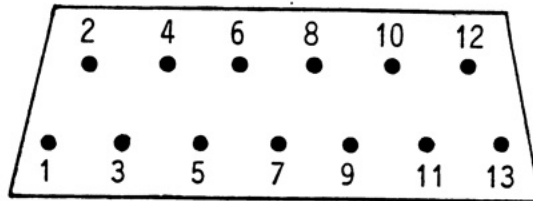

- |                 |                   |
|-----------------|-------------------|
| 1) Clock Input  | 8) Motor Control  |
| 2) Clock Output | 9) Proceed        |
| 3) Data Input   | 10) +5V/Ready     |
| 4) Ground       | 11) Audio Input   |
| 5) Data Output  | 12) Not Connected |
| 6) Ground       | 13) Interrupt     |
| 7) Command      |                   |

### SIO Connector Pin Assignments

### CONTROLLER JACK INTERFACES

The 800XL provides two controller jack interfaces. Both are functionally and electrically identical. The controller jacks are 9-pin D-type male connectors.

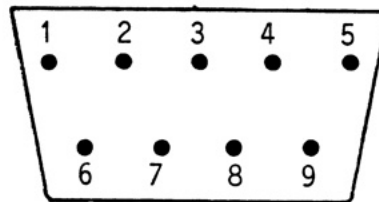

- |                            |                          |
|----------------------------|--------------------------|
| 1) Joystick Forward Input  | 6) Trigger Input         |
| 2) Joystick Backward Input | 7) +5 Volts              |
| 3) Joystick Left Input     | 8) Ground                |
| 4) Joystick Right Input    | 9) A Potentiometer Input |
| 5) B Potentiometer Input   |                          |

### Controller Jack Pin Assignments

## PARALLEL BUS INTERFACE

The parallel bus interface (PBI) provides an un-buffered, direct connection to the address, data and control signals shown below. It could be used to interface peripherals, parallel bus devices and external applications.

Ground	GND	1	2	EXTSEL	External Select
Address Output	A0	3	4	A1	Address Output
Address Output	A2	5	6	A3	Address Output
Address Output	A4	7	8	A5	Address Output
Address Output	A6	9	10	GND	Ground
Address Output	A7	11	12	A8	Address Output
Address Output	A9	13	14	A10	Address Output
Address Output	A11	15	16	A12	Address Output
Address Output	A13	17	18	A14	Address Output
Ground	GND	19	20	A15	Address Output
Data Bi-Directional	D0	21	22	D1	Data Bi-Directional
Data Bi-Directional	D2	23	24	D3	Data Bi-Directional
Data Bi-Directional	D4	25	26	D5	Data Bi-Directional
Data Bi-Directional	D6	27	28	D7	Data Bi-Directional
Ground	GND	29	30	GND	Ground
Phase 2 Clock Output	B02	31	32	GND	Ground
Reserved	NC	33	34	RST	Reset Output
Interrupt Request Input	IRQ	35	36	RDY	Ready Input
Reserved	NC	37	38	EXTENB	External Decoder Output
Reserved	NC	39	40	REF	Refresh Output
Column Address Output	CAS	41	42	GND	Ground
Math Pack Disable Input	MPD	43	44	RAS	Row Address Strobe Output
Ground	GND	45	46	LR/W	Latcher Read/Write Output
Reserved	NC	47	48	NC	Reserved
Audio Input	AUDIO	49	50	GND	Ground

PBI Connector Pin Assignments  
(Looking Into Computer)

## CARTRIDGE INTERFACE

The cartridge interface connects cartridges to the computer with a 30-pin connector.

The Atari 800XL has Revision B of Atari BASIC built-in. This is equivalent to having a BASIC cartridge "permanently" plugged into the console. When any cartridge is plugged into the computer, it takes precedence over the built-in BASIC. This is a function of hardware. When no cartridge is plugged in, the hardware enables the built-in BASIC.

	$\overline{S4}$	1	A	RD4	
	A3	2	B	GND	
	A2	3	C	A4	
	A1	4	D	A5	
	A $\emptyset$	5	E	A6	
	D4	6	F	A7	
	D5	7	H	A8	
BOTTOM	D2	8	J	A9	TOP
	D1	9	K	A12	
	D $\emptyset$	10	L	D3	
	D6	11	M	D7	
	$\overline{S5}$	12	N	A11	
	+5V	13	P	A10	
	RD5	14	R	R/W	
	$\overline{CCNTL}$	15	S	B $\emptyset$ Z	

Cartridge Connector Pin Assignments

## KEYBOARD INTERFACE

The keyboard has 55 alphanumeric keys (including special characters and controls), a spacebar, which interface through U24 and U25 Keyboard Sense/Scan Decoders, four function keys, and a RESET key.

## SECTION 2

### SELF TESTING

#### OVERVIEW

This section describes the Self Test procedure available for testing and trouble shooting the 800XL.

#### EQUIPMENT NEEDED

- \* 800XL Computer console with accessories
- \* TV set, properly adjusted

#### SELF TEST FEATURES

The Self Test feature allows minimal testing of the following components:

- \* Memory - RAM, ROM and ANTIC
- \* Audio/Visual - ANTIC, GTIA, and POKEY
- \* Keyboard - POKEY and ANTIC

NOTE: Remove any cartridge from the unit.

To enter the testing sequence, press and hold the OPTION key while the console is turned on. The Self Test menu screen will appear.

To exit the test, press the SYSTEM RESET key; the Basic Ready prompt will appear on the screen.

NOTE: Pressing the HELP key has no effect in any situation, except possible future application programs and as an exit from individual test to return to Self Test menu.

### Procedure:

1. Connect the computer console to TV set as shown in owner's manual.
2. Turn on TV set.
3. Press and hold the OPTION key as the computer is turned on until the Self Test menu appears.
4. The Self Test Menu displays four options:
  - \* Memory
  - \* Audio Visual
  - \* Keyboard
  - \* All Test

Press the SELECT key to move the selection indicator until you reach the desired test.

Press the START key to begin the test.

CAUTION: Self Test will not go into the Attract Mode. Do not leave Self Test screens on for any length of time (maximum seven minutes), since screen burning can occur.

### DESCRIPTION OF SELF TESTS

#### MEMORY TEST

Purpose: To test the ROM, RAM, and ANTIC chips.

Format: Two long bars displayed at the top of the screen represent the 16K Operating System ROM. Below them are 48 blocks, each representing 1K of RAM. The remaining 16K of RAM is available only with certain software programs and is not tested at this time. When either ROM or RAM is being tested, the corresponding bar segment color is white. If the ROM or RAM tests good, the bar color changes to light green. If the ROM or RAM tests defective, the color changes to red. Once a ROM or RAM has been tested and found defective the bar or specific block remains red and the memory is not tested again on subsequent test passes.

The MEMORY TEST continues testing until either the HELP or RESET key is pressed.

NOTE: If RESET is used to exit a test, the OS will return to BASIC not the Self Test. You must then press and hold OPTION and power up the console as before.



### AUDIO VISUAL TEST

**Purpose:** To test the ANTIC and POKEY chips.

**Format:** The screen displays a music staff and treble clef. A sequence of six tones sound and the corresponding note shows on the staff. The tune plays sequentially from channel one through channel four. The channel number changes for each according to the sound channel in use. Voice numbers 1-4 under the staff and treble clef indicate the channel in use. There is a slight pause between each voice. A fault is indicated by a note appearing on the screen without any sound and vice versa.

The AUDIO VISUAL TEST continues testing until either the HELP or RESET key is pressed.

### KEYBOARD TEST

**Purpose:** To test the POKEY, ANTIC and ROM chips.

**Format:** A full keyboard is displayed on the screen. Press each keyboard key and the corresponding key on the screen changes to inverse video and a tone sounds. It should change back to the original color when the key is released.

**NOTE:** The control and shift keys change only when pressed at the same time as another key. The display for both keys will change to inverse video and then back. As each key (except RESET, HELP and BREAK) is pressed, a tone is generated.

### ALL TESTS

All of the Self Tests are executed one after another until either the HELP or RESET key is pressed.

**NOTE:** When ALL TESTS is executing, the MEMORY TEST and the AUDIO VISUAL TEST exit after one complete test cycle. KEYBOARD TEST during ALL TESTS is software controlled. No operator input is required.

## SECTION 3

### DISASSEMBLY/ASSEMBLY

#### DISASSEMBLY

##### Hardware Access

- \* Turn unit upside down.
- \* Remove six screws from bottom cover.
- \* Turn unit upright.
- \* Tip cover by raising the left side allowing access to the keyboard cable. Carefully disconnect the keyboard ground strap and remove the keyboard cable from its socket and lay top aside.

NOTE: Due to incompatibility of plastic housings, do not interchange top or bottom housings between units. Keep the housings which belong to each unit with that unit.

##### Printed Circuit Board Removal

- \* Remove the four remaining screws holding the PC Board.
- \* Lift up on the front of the PC Board while pushing out on the right side of the bottom housing (player port side) until the player ports clear the bottom housing.
- \* Remove the PC Board.

##### Assembly

Reassemble in reverse order.

## SECTION 4

### TROUBLESHOOTING

The Troubleshooting Guide is designed to aid in arriving at rapid diagnosis of the following problems, listed in the most common order of failure. Each symptom is accompanied by some possible causes, and suggested solutions. Instructions for disassembly/assembly are in SECTION 3 of this manual.

<u>SYMPTOM</u>	<u>POSSIBLE CAUSES</u>	<u>SOLUTION</u>
Snowy Screen	TV Switch Box, ON/OFF switch, Channel Select switch, RF Modulator	Adjust or replace
	Defective Power Supply, Damaged RF Cable	Replace
	Defective (open) components on +5C line.	Isolate and replace
	Defective (shorted) components on +5A, B and/or C lines.	Isolate and replace
	Defective (shorted) LSI's and/or IC's	Isolate and repair
No Color or Bad Color	RF Modulator or R38	Adjust or replace
	U17, U20, Q1, Q3, CR2, CR3	Troubleshoot color/video circuitry; replace defective IC/component.
	Y1	Verify 3.579545 MHz freq. of Y1; replace if defective.

<u>SYMPTOM</u>	<u>POSSIBLE CAUSES</u>	<u>SOLUTION</u>
Black/Grey Screen	Y1, Q8, Q9, C109	Troubleshoot the clock circuit and replace defective component.
	U2, U7-20, U22, U23, U26-30	Isolate and replace defective IC
Yellow Screen	U28	Replace
Blue Screen	U2	Replace
Red/Brown Screen	U2-5, U18, U19, U28, U30	Isolate and replace defective IC

<u>SYMPTOM</u>	<u>POSSIBLE CAUSES</u>	<u>SOLUTION</u>
CPU Test Fail	Y1, Q8, Q9, U8	Verify 3.58 MHz osc. frequency; repair or replace.
RAM Test Failed	U2, U3, U9-16, U18, U19, U26-30	Verify ANTIC is <u>Rev. E.</u> ; repair or replace.
ROM Test Failed	U2-U5	Repair or replace
Video or ANTIC Stress Fail	U7	Repair or replace
GTIA Fail	U17	Replace
No Power Light (L1)	Power LED, Power Supply, Cables	Repair or replace
Console Game Switches Will Not Function	U17, Keyboard, Cable	Repair or replace
Tone or Tones Missing During Tone Test	U22, 4.5 MHz, U1, Audio Carrier Frequency, TV volume	Repair, adjust 4.5 MHz on RF Modulator; replace if necessary.
No Gray Bars or Missing Bar	U17, U20	Repair or replace
Upside Down Alpha/ Numerics on Player Field	U7	Replace
Some Keyboard Keys Fail*	U22, Keyboard, U24, U25, Cable	Repair or replace
All Keyboard Keys Fail	U22, U24, U25	Repair or replace
2-Way Clock Fail**	J1, U22	Repair or replace
External Audio**	J1, U1	Repair or replace

\* Keyboard and switch require operator intervention.

\*\* Requires the SuperSALT Test Assembly, jumper cables, power supply for correct operation. Joystick and Paddle Test require user action with a joystick and paddle during respective testing.

<u>SYMPTOM</u>	<u>POSSIBLE CAUSES</u>	<u>SOLUTION</u>
<u>I/O Port Test Failures:</u>		
PIA Ports	U23, C26-29, C82-92 L19-22	Repair or replace
SIO Port	U22, U23, C75-78	Repair or replace
POT Lines	U22, L15-18, C71-74 C63-66	Repair or replace
Trigger Lines	U17, L23, L30, C96, C97	Repair or replace
Voltage: P1, P2	L25, J5, J6	Inspect J5, J6 for damaged pins; replace as necessary.
Voltage: MC	Q7, L11, U2	Repair or replace
Timers	U22	Replace

## SECTION 5

### SCHEMATIC AND PARTS LIST

The schematic for the 800XL computer is attached to this manual.

The schematic is a domestic and U.K. version. All U.K. additions are shown in dotted boxes. Read the notes at the bottom of the schematic before any troubleshooting is performed.

The following is the complete parts list for the 800XL computer.

## PARTS LIST

<u>LOCATION</u>	<u>DEVICE</u>	<u>ATARI PART NUMBER</u>
	<b>Console Assembly</b>	
	Door, Cartridge	C0245822-001
	Bar, Door	C024680-001
	Spring, Door	C024681-001
	Keyboard	C061983
	<b>Power Supply</b>	CA024814-001
	<b>T.V. Switchbox (Pkgd.)</b>	CA014746
	<b>RF Cable</b>	CA024624-001
	<b>PCB Assembly</b>	
	Cartridge Guide	C060297
	Shield, Top	C024467-001
	Shield, Bottom	C024468-001
A1	Modulator, Domestic (UM1652)	CA061619
C1	Cap. Elec. Axial 470 $\mu$ F (10V)	C014370
C2,3	Cap. Elec. Axial 22 $\mu$ F (16V)	C014393
C4	Cap. Ceramic Axial .01 $\mu$ F (25V)	C014181-02
C5, 6	Cap. Ceramic Axial .001 $\mu$ F (50V)	C014181-01
C7	Cap. Ceramic Axial .01 $\mu$ F (25V)	C014181-02
C8,9	Cap. Ceramic Axial .001 $\mu$ F (50V)	C014181-01
C10	Cap. Elec. Axial 22 $\mu$ F (16V)	C014393
C11	Cap. Ceramic Axial .01 $\mu$ F (25V)	C014181-02
C12	Cap. Ceramic Axial .001 $\mu$ F (50V)	C014181-01
C13	Cap. Ceramic Axial .01 $\mu$ F (25V)	C014181-02
C14,15	Cap. Ceramic Axial .001 $\mu$ F (50V)	C014181-01
C16	Cap. Ceramic Axial .1 $\mu$ F (25V)	C014181-03
C17	Cap. Ceramic Axial .047 $\mu$ F (50V)	C014180-09
C18	Cap. Ceramic Axial .1 $\mu$ F (25V)	C014181-03
C19,20	Cap. Nonpolarized 4.7 $\mu$ F (35V)	C061647
C21	Cap. Ceramic Axial .001 $\mu$ F (50V)	C014181-01
C22	Cap. Nonpolarized 4.7 $\mu$ F (35V)	C06147
C23	Cap. Ceramic Axial .001 $\mu$ F (50V)	C014180-09
C24	Cap. Elec. Alum 10 $\mu$ F (16V)	C014371
C25-32	Cap. Ceramic Axial .1 $\mu$ F (25V)	C014181-03
C33	(not used)	
C34-43	Cap. Ceramic Axial .1 $\mu$ F (25V)	C014181-03



<u>LOCATION</u>	<u>DEVICE</u>	<u>ATARI PART NUMBER</u>
C44	Cap. Ceramic Axial 68pF (50V)	C014179-12
C45	Cap. Ceramic Axial 220pF (50V)	C014180-05
C46,47	Cap. Ceramic Axial .001μF (50V)	C014181-01
C48	Cap. Ceramic Axial .1μF (25V)	C014181-03
C49	Cap. Elec. Axial 47μF (10V)	24-100476
C50	Cap. Elec. Alum 10μF (16V)	C014371
C51	Cap. Ceramic Axial .1μF (25V)	C014181-03
C52	Cap. Ceramic Axial 100pF (50V)	C014179-19
C53	Cap. Ceramic Axial 3.9pF	C061336-01
C54	Cap. Ceramic Axial .001μF (50V)	C014181-01
C55	Cap. Ceramic Axial 100pF (50V)	C014179-19
C56	(not used)	
C57	Cap. Ceramic Axial .1μF (25V)	C014181-03
C58-61	(not used)	
C62	Cap. Ceramic Axial .1μF (25V)	C014181-03
C63-66	Cap. Ceramic Axial .047μF (35V)	C014180-09
C67	(not used)	
C68-70	Cap. Ceramic Axial .1μF (25V)	C014181-03
C71-78	Cap. Ceramic Axial .001μF (50V)	C014181-01
C79	Cap. Elec. Axial 22μF (16V)	C014393
C80-92	Cap. Ceramic Axial .001μF (50V)	C014181-01
C93	Cap. Ceramic Axial .1μF (25V)	C014181-03
C94,95	Cap. Ceramic Axial .01μF (25V)	C014181-02
C96,97	Cap. Ceramic Axial .001μF (50V)	C014181-01
C98	Cap. Elec. Alum 10μF (16V)	C014371
C99-101	(not used)	
C102	Cap. Ceramic Axial .001μF (50V)	C014181-01
C103,104	(not used)	
C105-109	Cap. Ceramic Axial .1μF (25V)	C014181-03
C110,111	(not used)	
C112	Cap. Ceramic Axial .001μF (50V)	C014181-01
CR1-5	Diode (1N4148)	C060607
J1	Connector, Rt. Angle (13 pin)	C012995
J2	Connector, Monitor (5 pin)	C014388
J3	(not used)	
J4	Connector, Cartridge (30 pin)	C014389
J5,6	Connector, Rt. Angle (9-pin)	C010448
J7	Connector, DIN Power (7 pin)	C061838
J8	Connector, Keyboard Header (24 pin)	C061793
L1-3	Inductor, Ferrite Bead	C014384
L4,5	Inductor, Axial 820μH	C017948-03
L6	Inductor, Axial 100μH	C017948-04
L7	Inductor, Ferrite Bead	C014384
L8	(not used)	
L9	Inductor, Ferrite Bead	C014384
L10	Inductor, Axial 10μH	C014381

<u>LOCATION</u>	<u>DESCRIPTION</u>	<u>ATARI PART NUMBER</u>
L11,12	Inductor, Ferrite Bead	C014384
L13	(not used)	
L14	Inductor, Axial 22 $\mu$ H	C014380
L15-30	Inductor, Axial 10 $\mu$ H	C014381
Q1-5	Transistor, NPN (2N3904)	34-2N3904
Q6	(not used)	
Q7	Transistor, PNP (MPSA55)	C014809
Q8,9	Transistor, PNP (2N3906)	C018991
R1	Resistor, 1/4W 2.2K	14-5222
R2	Resistor, 1/4W 2K	14-5202
R3	Resistor, 1/4W 6.2K	14-5563
R4	Resistor, 1/4W 56K	14-5563
R5	Resistor, 1/4W 470K	14-5474
R6	Resistor, 1/4W 68K	14-5683
R7	Resistor, 1/4W 2K	14-5202
R8	Resistor, 1/4W 5.1K	14-5512
R9	Resistor, 1/4W 3.3K	14-5332
R10	Resistor, 1/4W 1K	14-5102
R11	Resistor, 1/4W 2.2K	14-5222
R12	Resistor, 1/4W 3K	14-5302
R13,14	Resistor, 1/4W 1K	14-5102
R15,16	Resistor, 1/4W 3K	14-5301
R17	Resistor, 1/4W 240 Ohm	14-5241
R18	Resistor, 1/4W 1M	14-5105
R19-22	Resistor, 1/4W 3K	14-5302
R23-30	Resistor, 1/4W 10K	14-5103
R31-34	Resistor, 1/4W 3K	14-5302
R35	Resistor, 1/4W 33K	14-5333
R36	Resistor, 1/4W 680 Ohm	14-5681
R37	Resistor, 1/4W 1K	14-5102
R38	Resistor, Variable (Trimpot) 500K	19-411504
R39	Resistor, 1/4W 56K	14-5563
R40	Resistor, 1/4W 100 Ohm	14-5101
R41-45	Resistor, 1/4W 1K	14-5102
R46	Resistor, 1/4W 1.6K	14-5162
R47	Resistor, 1/4W 36K	14-5363
R48	Resistor, 1/4W 18K	14-5183
R49	Resistor, 1/4W 9.1K	14-5912
R50	Resistor, 1/4W 4.7K	14-5472
R51	Resistor, 1/4W 750 Ohm	14-5751
R52	Resistor, 1/4W 2K	14-5202
R53	Resistor, 1/4W 100 Ohm	14-5101
R54	Resistor, 1/4W 1.2K	14-5122
R55-57	Resistor, 1/4W 75 Ohm	14-5750
R58	Resistor, 1/4W 6.2K	14-5622
R59	Resistor, 1/4W 2.2K	14-5222

<u>LOCATION</u>	<u>DESCRIPTION</u>	<u>ATARI PART NUMBER</u>
R60,61	Resistor, 1/4W 1K	14-5102
R62	Resistor, 1/4W 3.3K	14-5332
R63	Resistor, 1/4W 4.7K	14-5472
R64	Resistor, 1/4W 10K	14-5103
R65	Resistor, 1/4W 240 Ohm	14-5241
R66	Resistor, 1/4W 100 Ohm	14-5101
R67	(not used)	
R68	Resistor, 1/4W 3K	14-5302
R69-73	(not used)	
R74-75	Resistor, 1/4W 3K	14-5302
R76-79	Resistor, 1/4W 1.8K	14-5182
R80	Resistor, 1/4W 1K	14-5102
R81-84	Resistor, 1/4W 4.7K	14-5472
R85-88	Resistor, 1/4W 3K	14-5302
R89	(not used)	
R90	Resistor, 1/4W 100 Ohm	14-5101
R91	Resistor, 1/4W 2.7K	14-5272
R92-94	Resistor, 1/4W 4.7K	14-5472
R95	Resistor, 1/4W 220 Ohm	14-5221
R96	(not used)	
R97	Resistor, 1/4W 1K	14-5102
R98-105	Resistor, 1/4W 33 Ohm	14-5330
R106	(not used)	
R107,108	Resistor, 1/4W 33 Ohm	14-5330
R109	Resistor, 1/4W 100 Ohm	14-5101
R110	Resistor, 1/4W 220 Ohm	14-5221
R111	Resistor, 1/4W 27 Ohm	14-5270
R112	Resistor, 1/4W 100 Ohm	14-5101
R113	Resistor, 1/4W 470 Ohm	14-5471
R114	Resistor, 1/4W 1.5K	14-5152
R115	(not used)	
R116	Resistor, 1/4W 51 Ohm	14-5152
R117	Resistor, 1/4W 100 Ohm	14-5101
R118	Resistor, 1/4W 220 Ohm	14-5221
R119	Resistor, 1/4W 100 Ohm	14-5101
R120-127	Resistor, 1/4W 220 Ohm	14-5221
R128-131	Resistor, 1/4W 100 Ohm	14-5101
R132,133	Resistor, 1/4W 220 Ohm	14-5221
R134-137	Resistor, 1/4W 470 Ohm	14-5471
RN1-4	Resistor Network, SIP 470 Ohm	C061668-04
S1	Switch, Vertical Power (SPDT)	C061022
S2	Switch, Channel Select	C019702-01
U1	IC Dual Op Amp (LM358)	C061702
U2	IC Decoder (74LS138)	C061428
U3	IC Mem Mngt Unit (MMuI B)	C061618
U4	IC (8K x 8) Basic ROM Rev B	C060302
U5	IC (16K x 8) OS ROM	C061598

<u>LOCATION</u>	<u>DESCRIPTION</u>	<u>ATARI PART NUMBER</u>
U6	(not used)	
U7	IC ANTIC	C021697
U8	IC CPU (6502)	C014806
U9-16	IC (64K X 1 DRAM)	C060612
U17	IC GTIA	C014805
U18	IC AND Quad (74LS08)	C017097
U19	IC Hex Inverter (74LS14)	C061850
U20	IC Hex Buffer CMOS (CD4050B)	C010816
U21	(not used)	
U22	IC POKEY	C012294
U23	IC PIA	C014795
U24,25	IC MUX (CD4051B)	C014336
U26,27	IC Multiplexer (74LS158)	C014345
U28	IC Latch (74LS375)	C060619
U29	IC Delay Module	C060472
U30	IC AND/OR Inverter (74LS51)	C060474
W1	Resistor, 1/4W 0 Ohm	C060629
XU1	Socket, IC (8 pin)	C014386-01
XU2	Socket, IC (16 pin)	C014386-03
XU3	Socket, IC (20 pin)	C014386-05
XU4,5	Socket, IC (24 pin)	C014386-07
XU6	(not used)	
XU7,8	Socket, IC (40 pin)	C014386-09
XU9-16	Socket, IC (16 pin)	C014386-03
XU17	Socket, IC (40 pin)	C014386-09
XU18,19	Socket, IC (14 pin)	C014386-02
XU20	Socket, IC (16 pin)	C014386-03
XU21	(not used)	
XU22,23	Socket, IC (40 pin)	C014386-09
XU24-28	Socket, IC (16 pin)	C014386-03
XU29	(not used)	
XU30	Socket, IC (14 pin)	C014386-02
Y1	Crystal, 3.579545 MHz	C061090



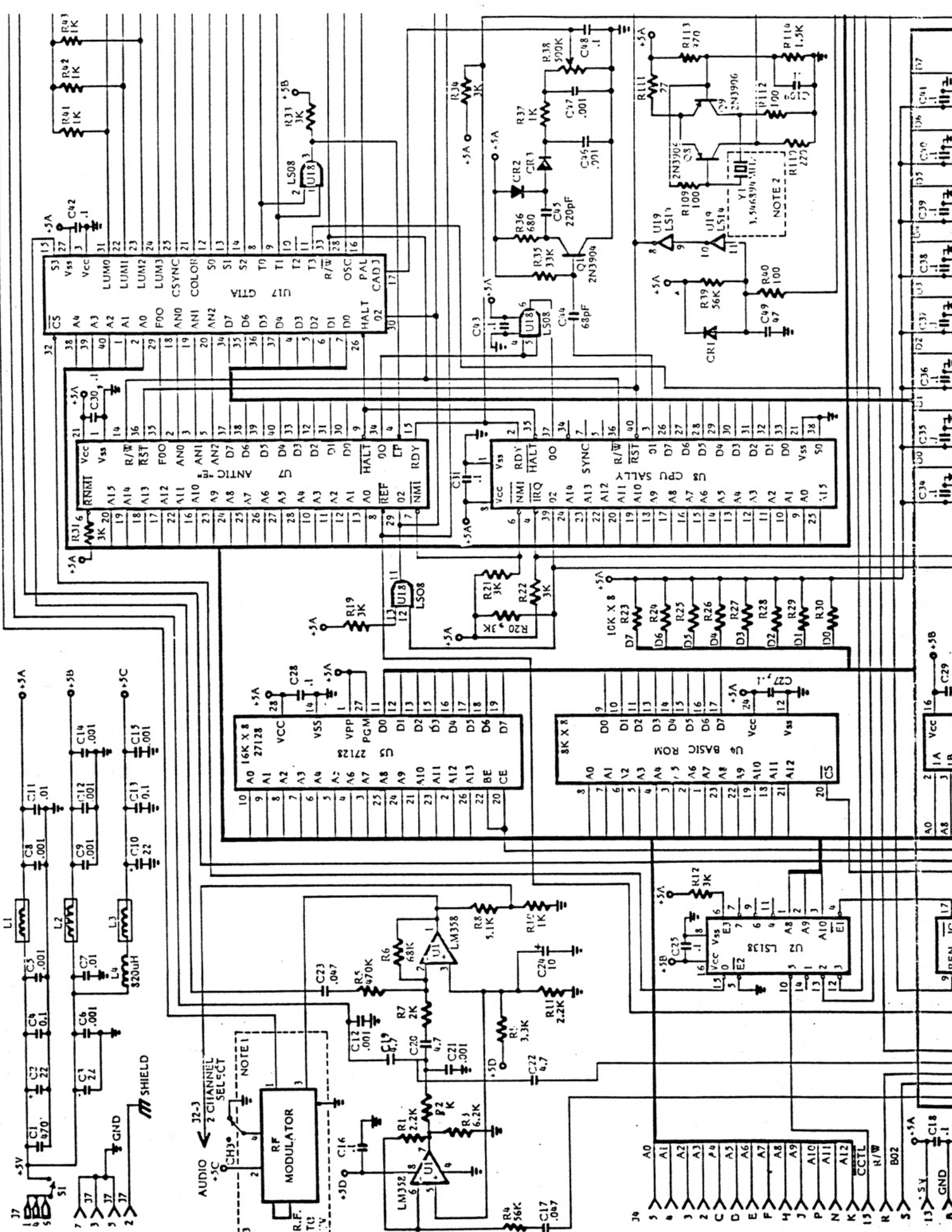

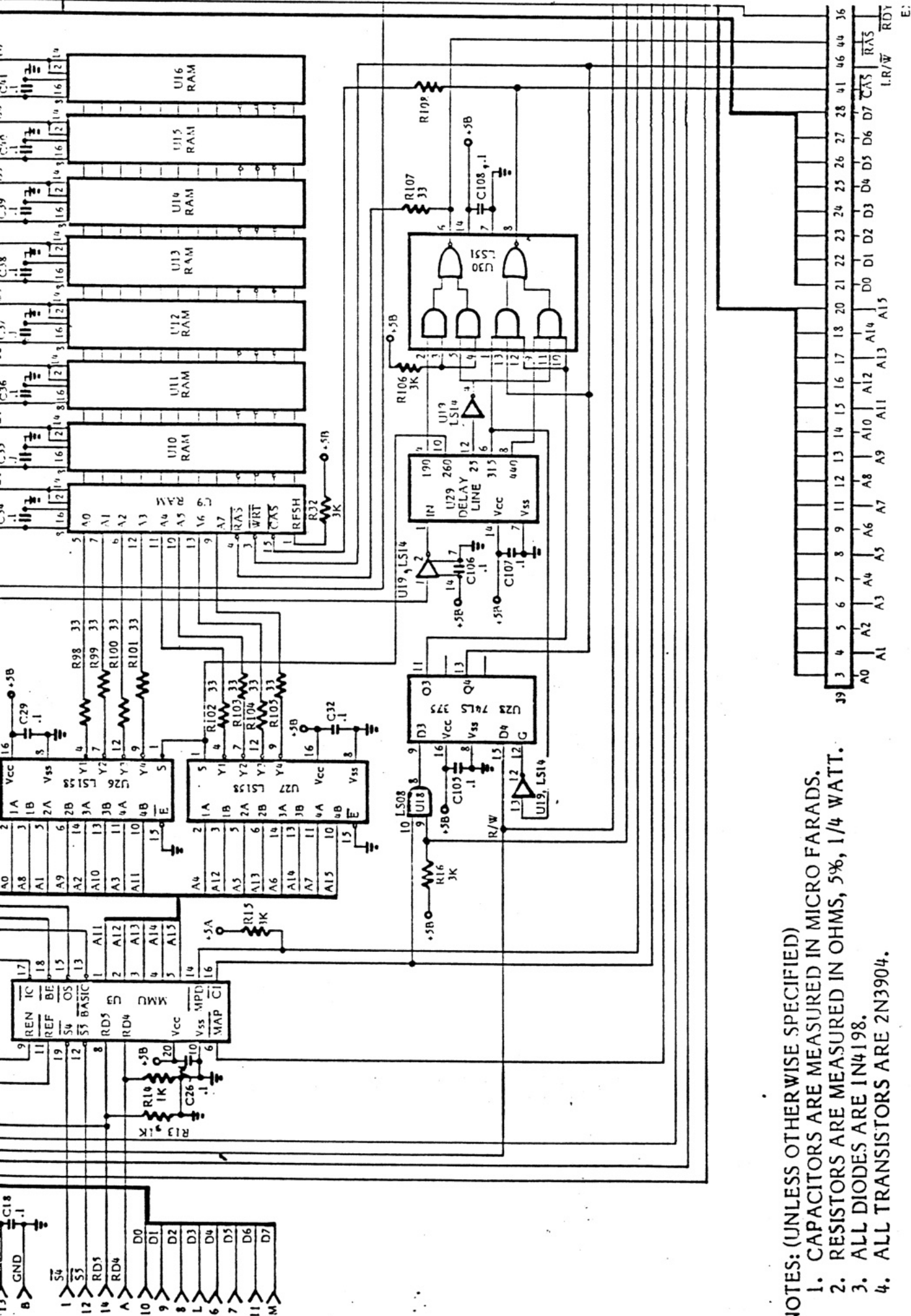

- NOTES: (UNLESS OTHERWISE SPECIFIED)
1. CAPACITORS ARE MEASURED IN MICRO FARADS.
  2. RESISTORS ARE MEASURED IN OHMS, 5%, 1/4 WATT.
  3. ALL DIODES ARE 1N4198.
  4. ALL TRANSISTORS ARE 2N3904.

- NOTES FOR DOMESTIC UNITS ONLY
1. CHANGE MODULATOR UMI662 (C061658) TO MODULATOR UMI652 (CA061619).
  2. CHANGE Y1 CRYSTAL, C01510, 3.546894MHZ TO C061090, 3.579545MHZ.
  3. DELETE ALL THESE COMPONENTS.
  4. ADD JUMPER W2 FOR DOMESTIC.

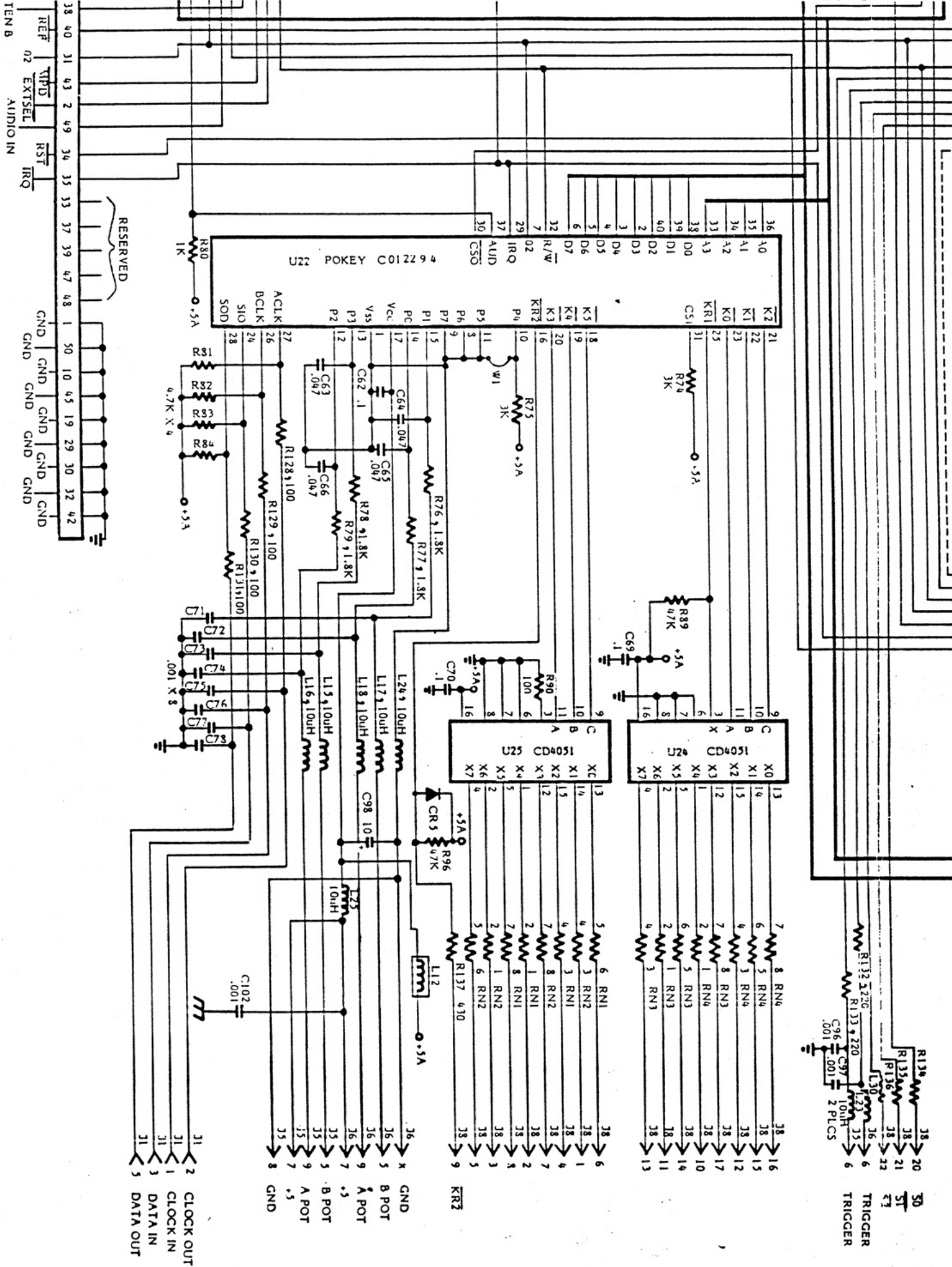

800 XI SCHEMATIC



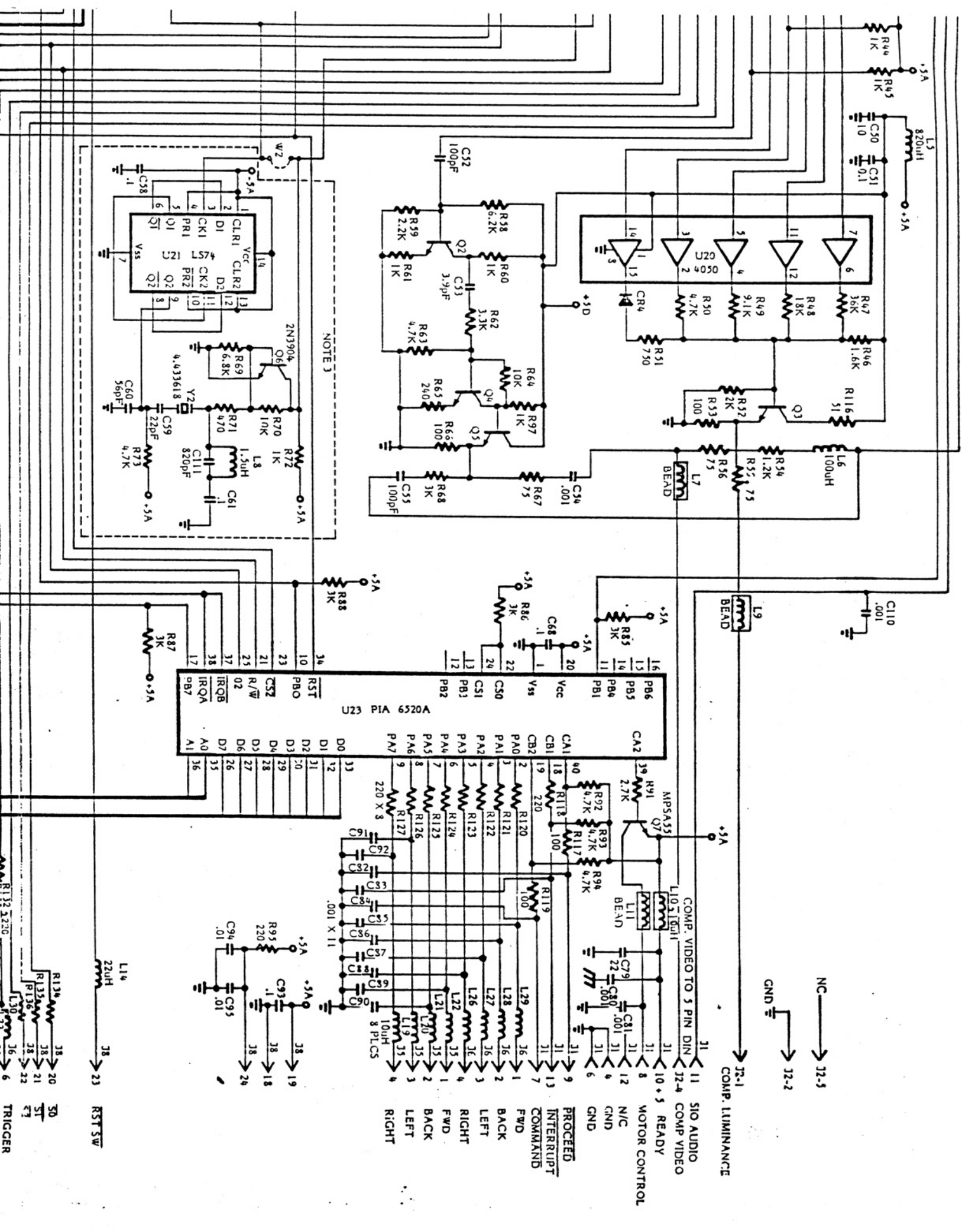

NOTE 3

NOTE 3

U23 PIA 6520A

NC → 32-5  
 GND → 32-2

31 SJ0 AUDIO  
 11 COMP VIDEO  
 32-4 COMP VIDEO  
 10-5 READY  
 MOTOR CONTROL  
 N/C  
 GND  
 GND  
 GND  
 9 PROCEED  
 8 INTERRUPT  
 7 COMMAND  
 6 FWD  
 5 BACK  
 4 LEFT  
 3 RIGHT  
 2 FWD  
 1 BACK  
 4 LEFT  
 3 RIGHT

38 RST SW  
 50 TRIGGER